



US006646864B2

(12) **United States Patent**
Richardson

(10) **Patent No.:** **US 6,646,864 B2**
(45) **Date of Patent:** **Nov. 11, 2003**

(54) **PROTECTIVE CASE FOR TOUCH SCREEN DEVICE**

(75) Inventor: **Curtis R. Richardson**, Fort Collins, CO (US)

(73) Assignee: **Otter Products, LLC**, Fort Collins, CO (US)

(*) Notice: Subject to any disclaimer, the term of this patent is extended or adjusted under 35 U.S.C. 154(b) by 0 days.

(21) Appl. No.: **10/300,200**

(22) Filed: **Nov. 19, 2002**

(65) **Prior Publication Data**

US 2003/0095374 A1 May 22, 2003

Related U.S. Application Data

(60) Provisional application No. 60/335,865, filed on Nov. 19, 2001.

(51) **Int. Cl.**⁷ **G06F 1/16**

(52) **U.S. Cl.** **361/681**; 361/683; 206/305; 312/223.1

(58) **Field of Search** 361/679-681, 361/683; 379/433; 312/223.2

(56) **References Cited**

U.S. PATENT DOCUMENTS

2,392,787 A	1/1946	Vermot	58/99
3,590,988 A	7/1971	Hollar	206/45
4,703,161 A	10/1987	McLean	235/1

4,762,227 A	8/1988	Patterson	206/328
5,092,459 A	3/1992	Uljanic et al.	206/320
5,175,873 A	* 12/1992	Goldenberg et al.	455/351
6,031,524 A	* 2/2000	Kunert	345/173
6,041,924 A	3/2000	Tajima	206/320
6,049,813 A	4/2000	Danielson et al.	708/100
6,215,474 B1	4/2001	Shah	345/168
6,239,968 B1	5/2001	Kim et al.	361/679
6,273,252 B1	8/2001	Mitchell	206/320
6,301,100 B1	10/2001	Iwata	361/683
6,313,982 B1	11/2001	Hino	361/679
6,317,313 B1	11/2001	Mosgrove et al.	361/680
6,445,577 B1	9/2002	Madsen et al.	361/683
6,456,487 B1	* 9/2002	Hetterick	361/683
6,519,141 B2	* 2/2003	Tseng et al.	361/683
2002/0101707 A1	8/2002	Canova, Jr. et al.	361/683

* cited by examiner

Primary Examiner—Darren Schuberg

Assistant Examiner—Anthony Q. Edwards

(74) *Attorney, Agent, or Firm*—The Law Offices of William W. Cochran, LLC

(57) **ABSTRACT**

Discloses is a protective case for an electronic device that has a touch screen. The touch screen is protected with a membrane adapted to the specific contour and profile of the electronic device and allows the user to use the touch screen interface with no shortcomings. The protective case is further adapted to allow infrared and other communication signals while the device is secured inside the case. Further, electrical connections can be made through the case without affecting the protection afforded the electronic device inside.

16 Claims, 12 Drawing Sheets

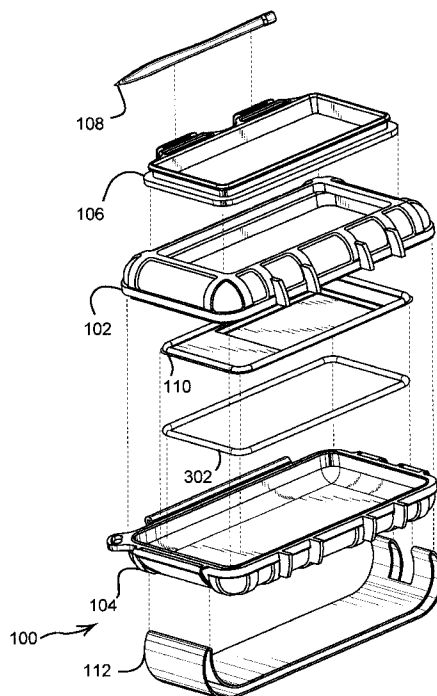

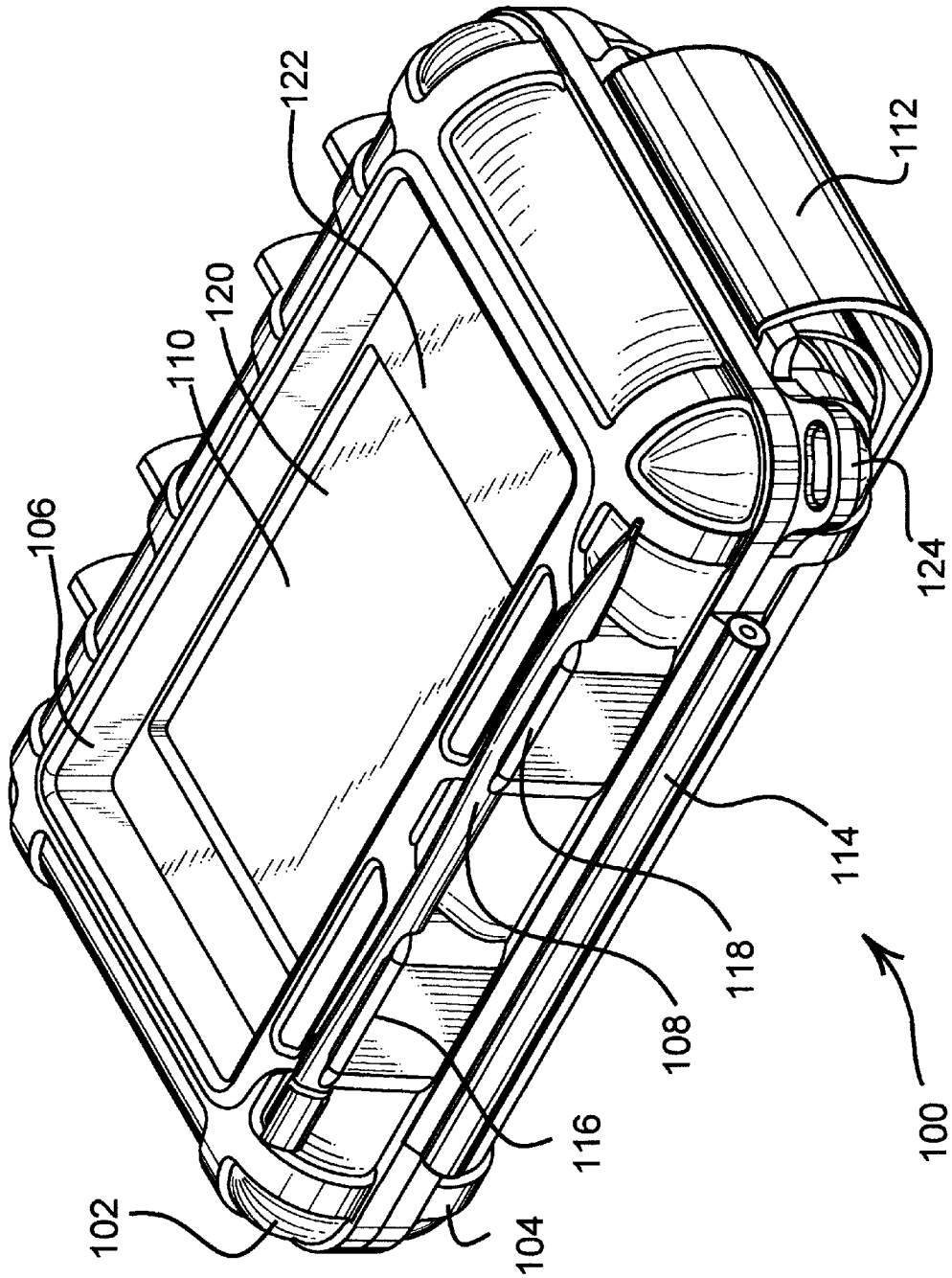

FIGURE 1

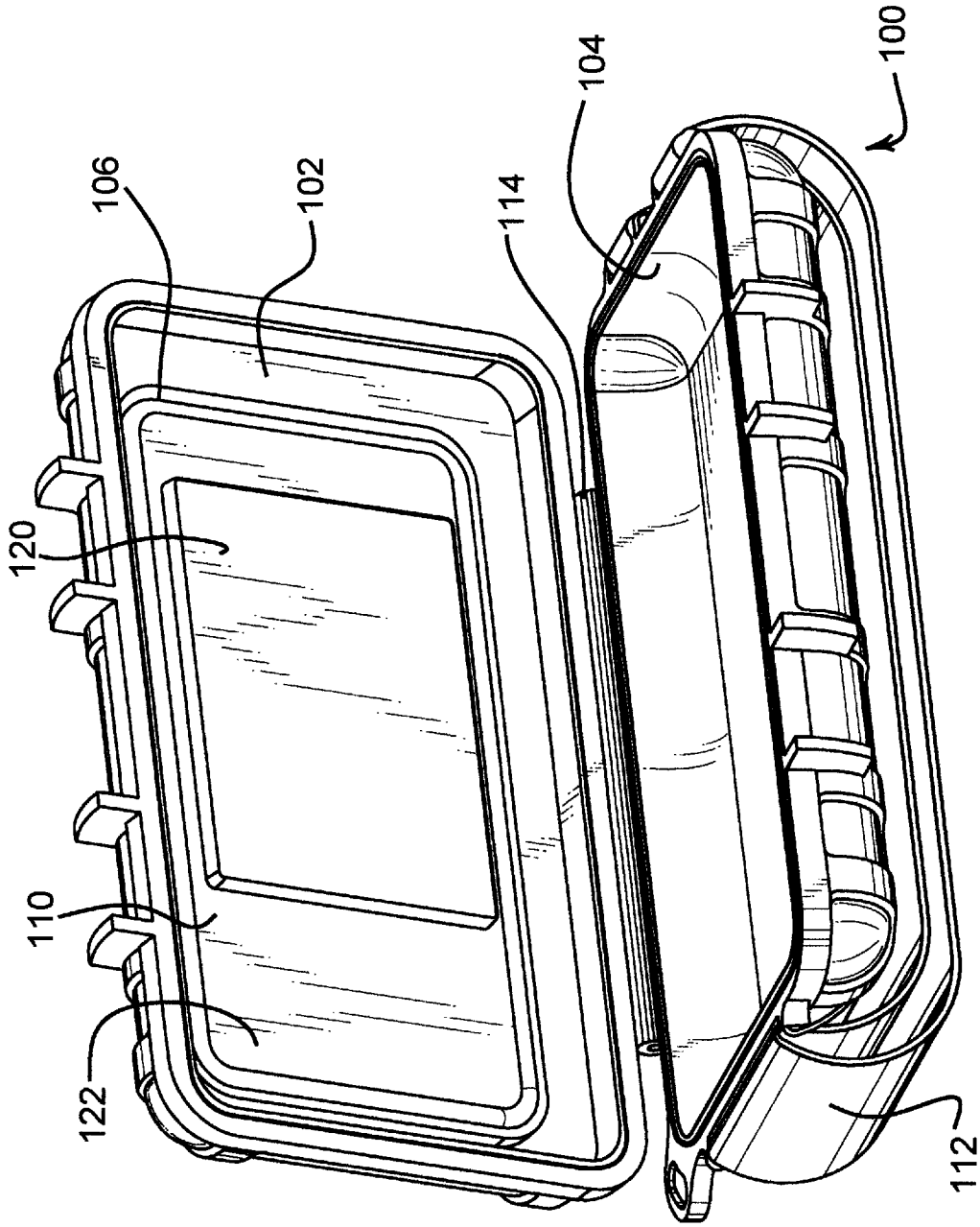

FIGURE 2

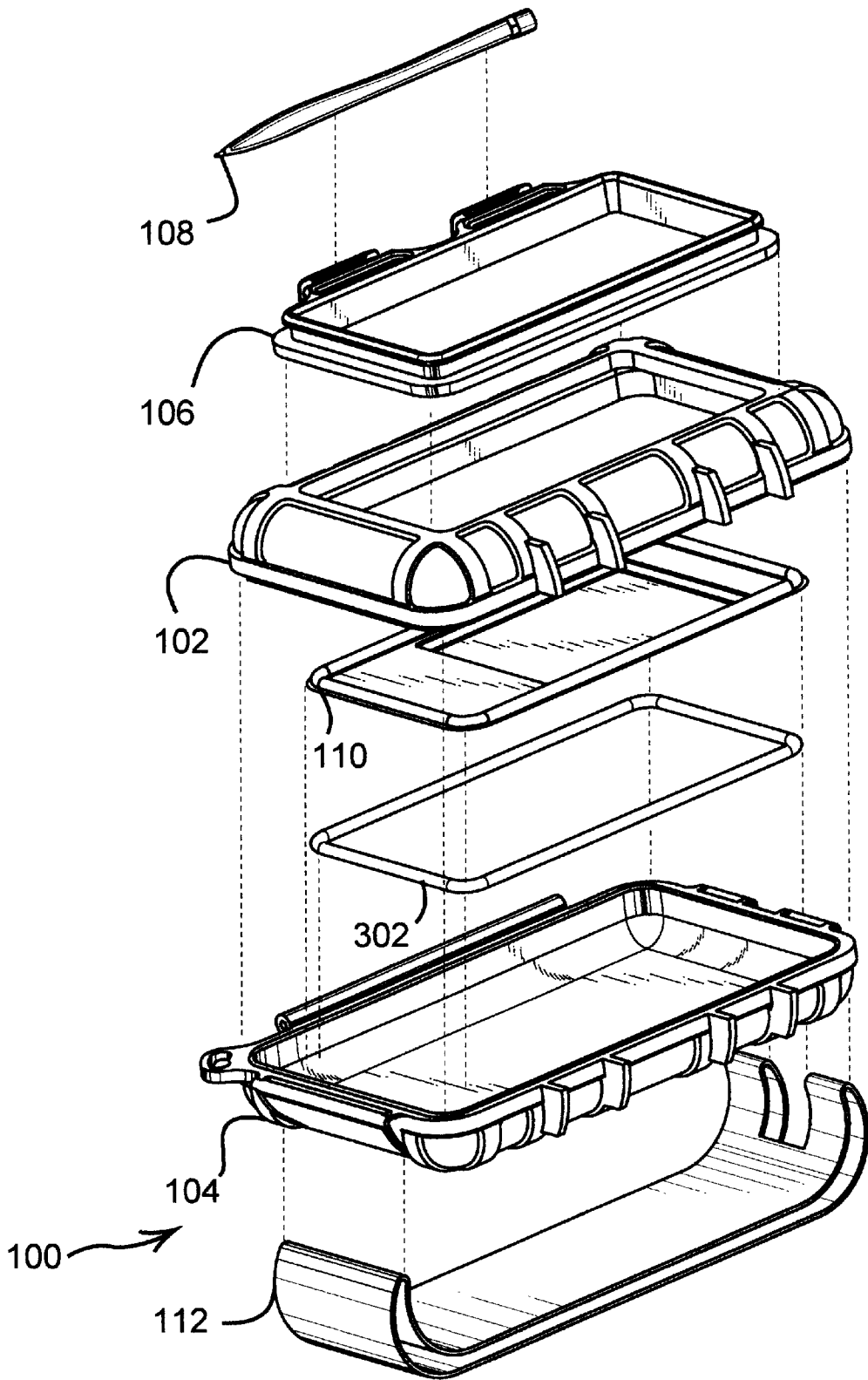

FIGURE 3

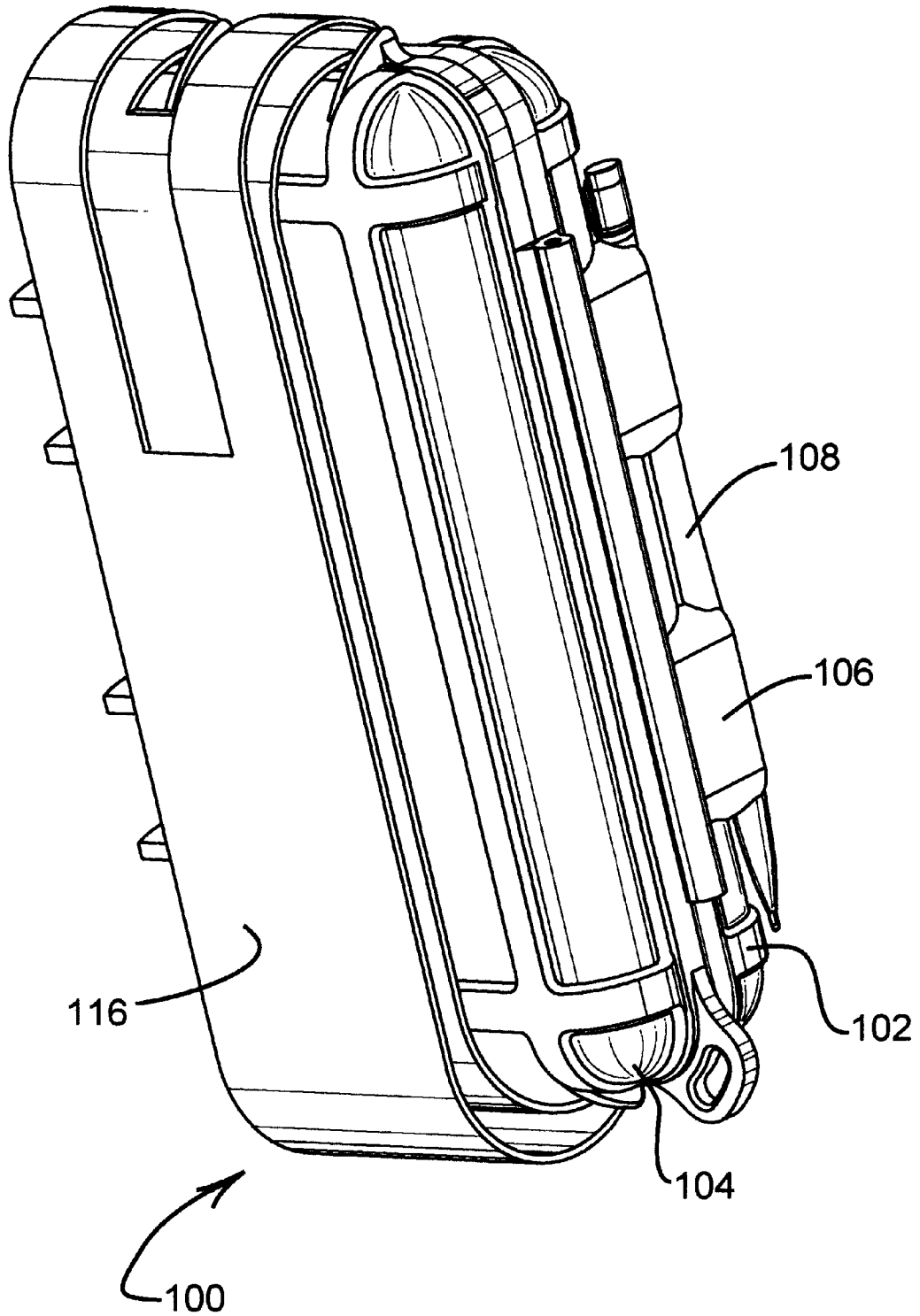

FIGURE 4

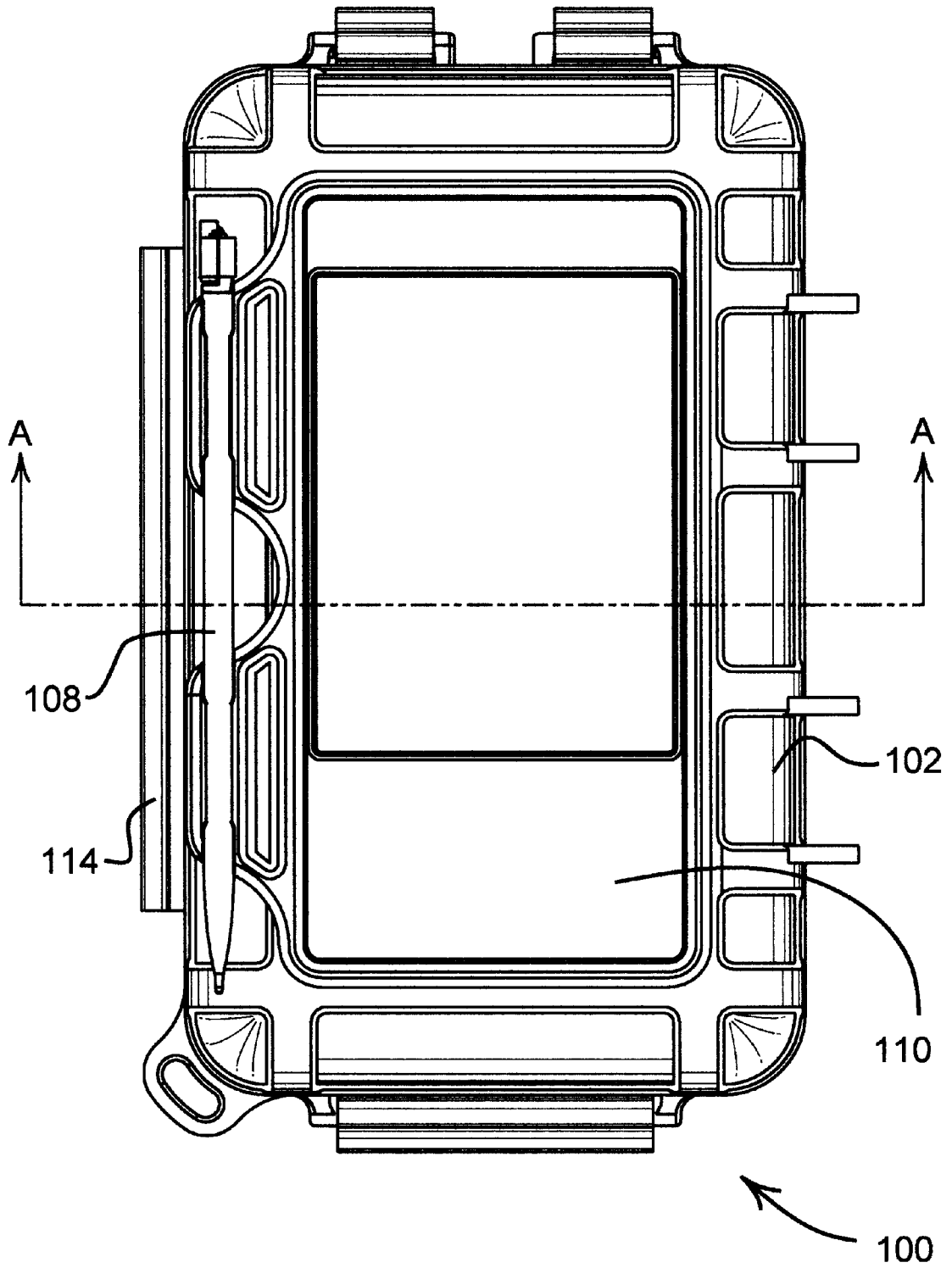

FIGURE 5

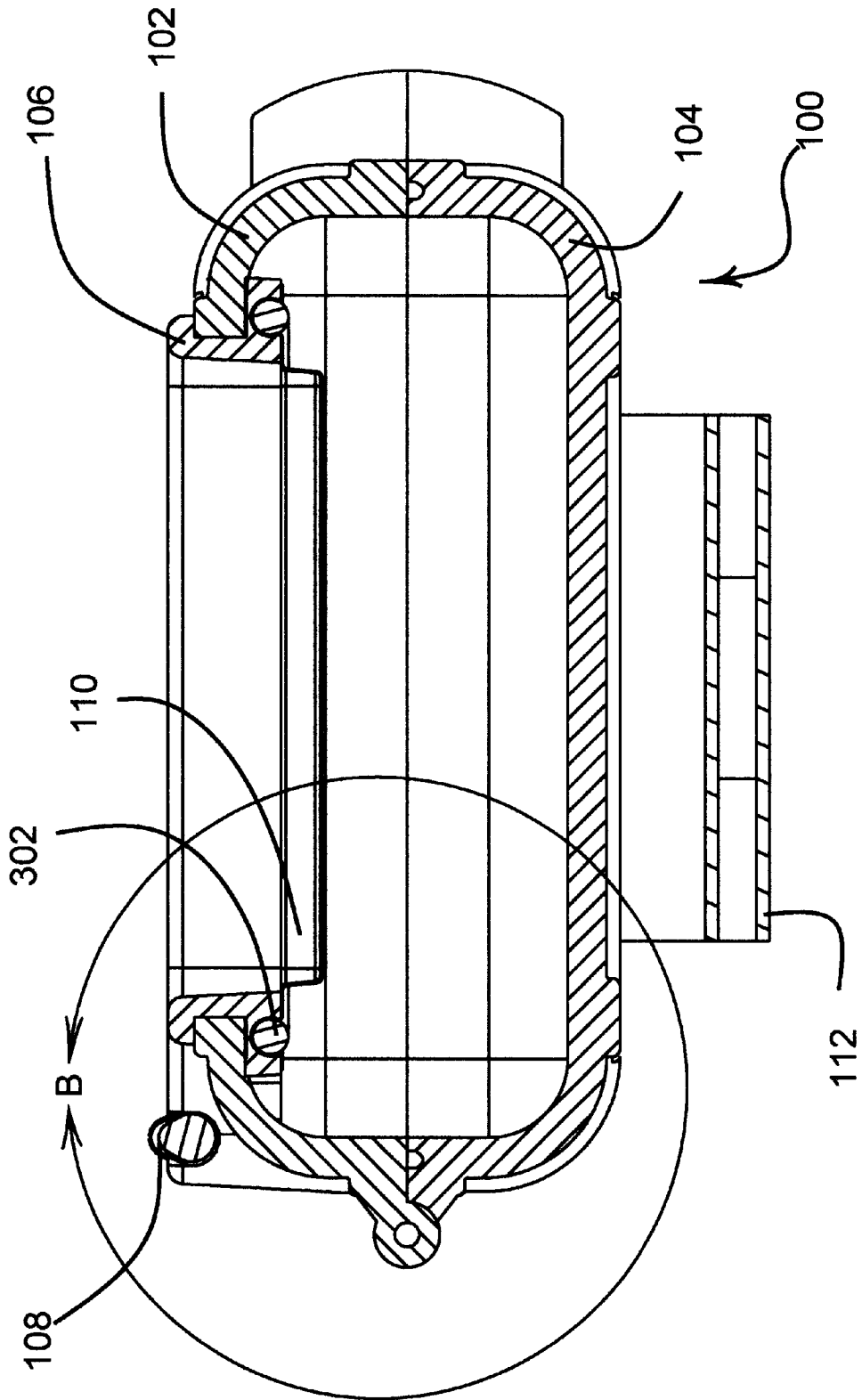

FIGURE 6

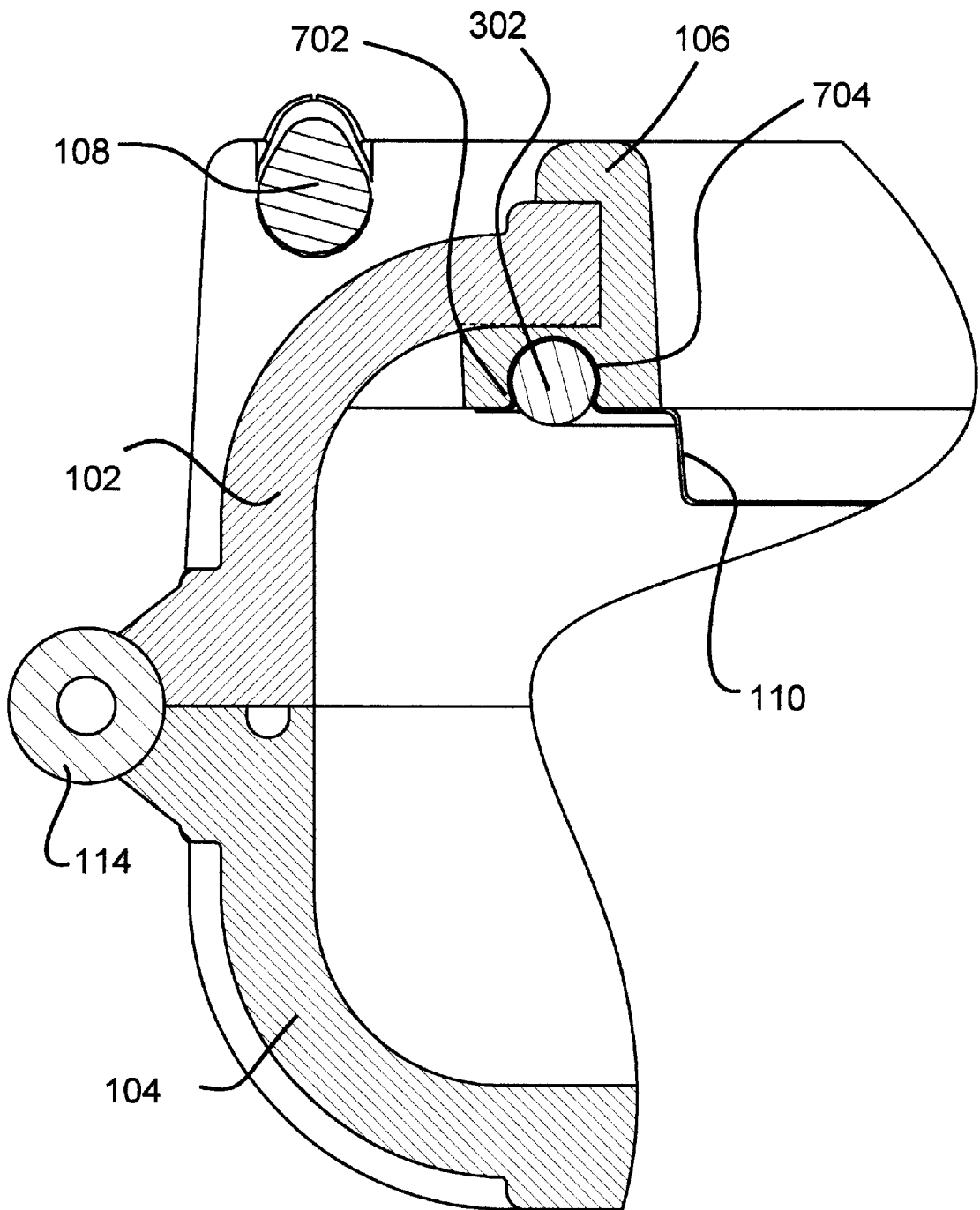

FIGURE 7

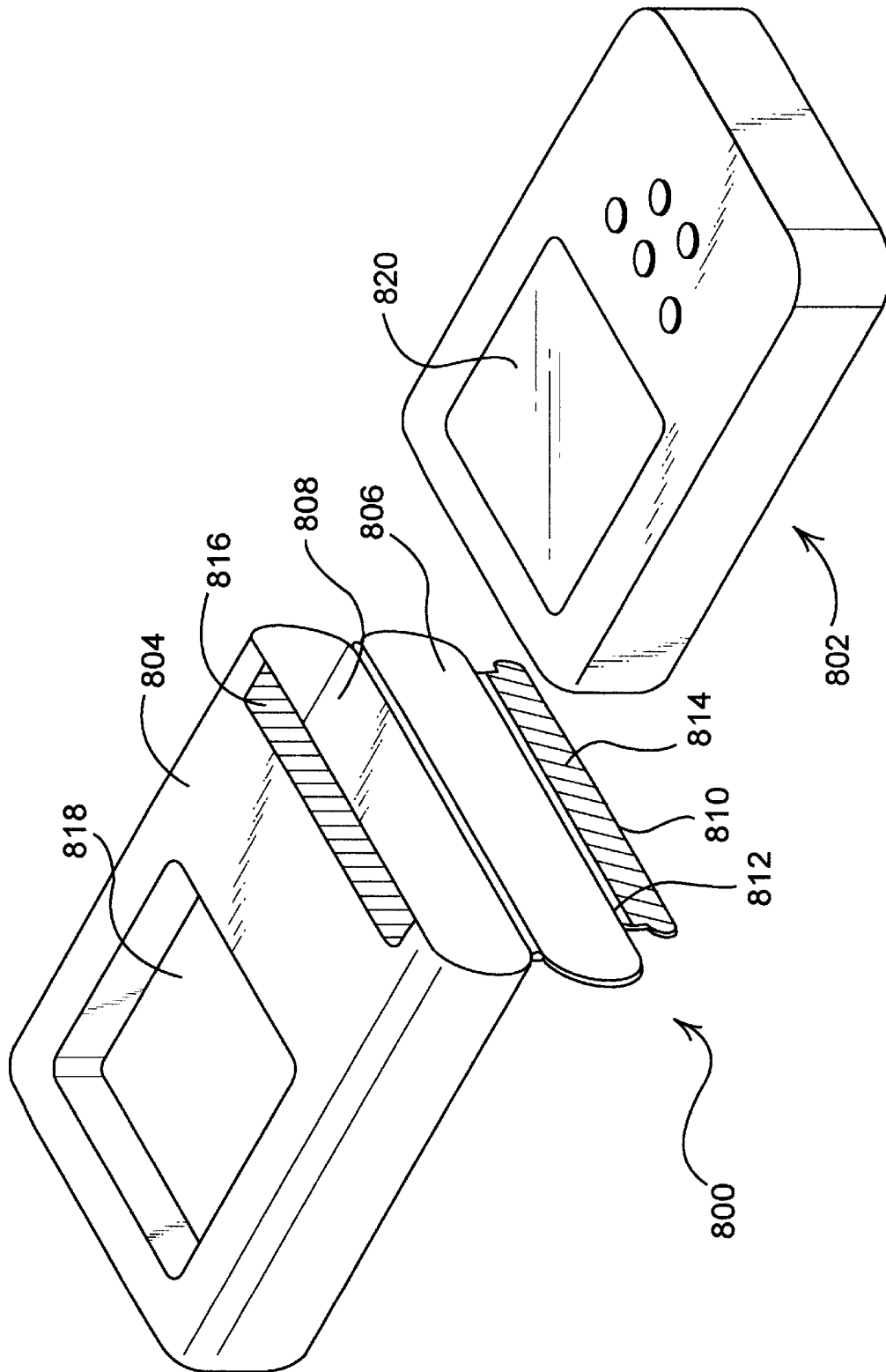

FIGURE 8

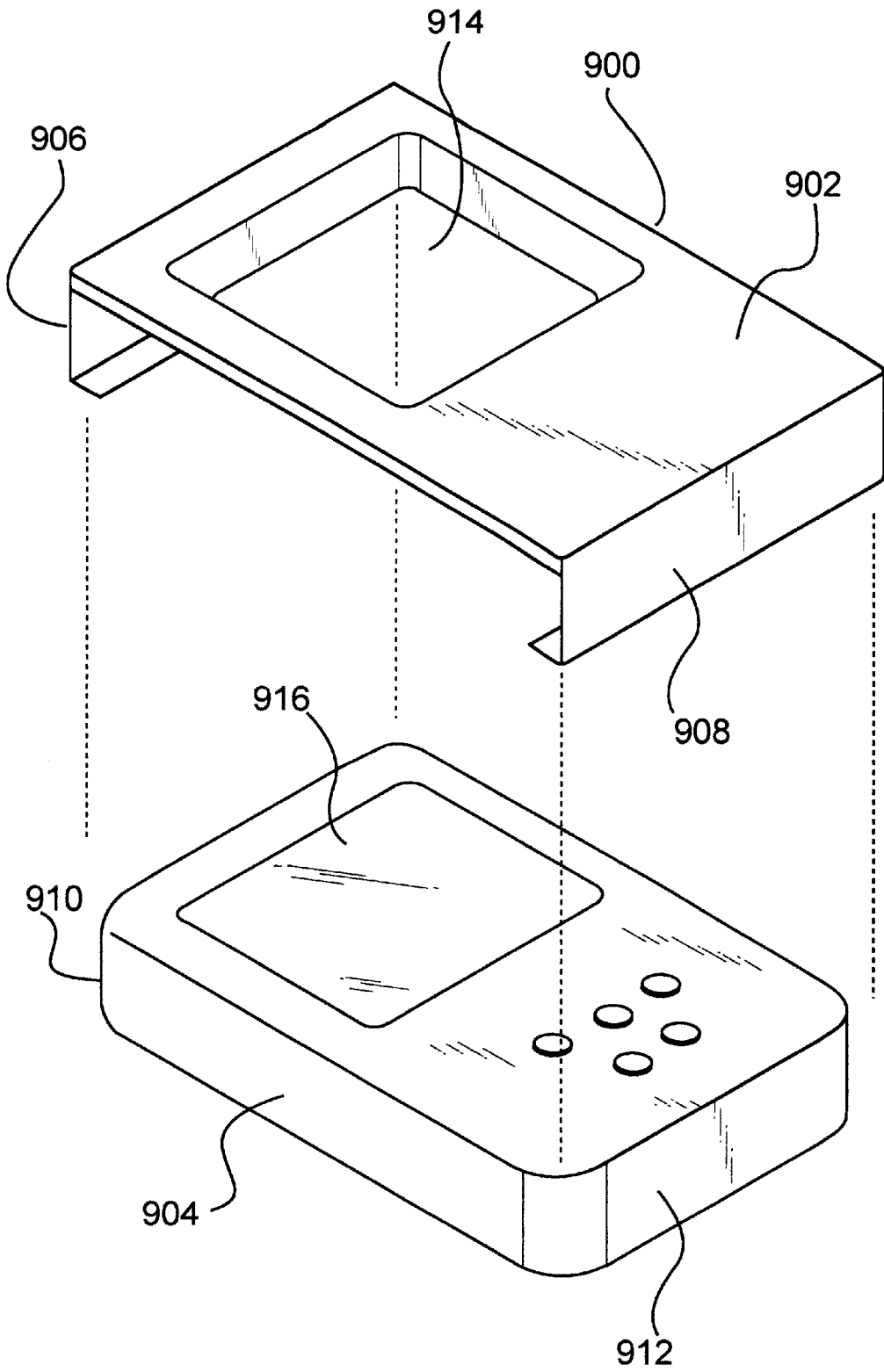

FIGURE 9

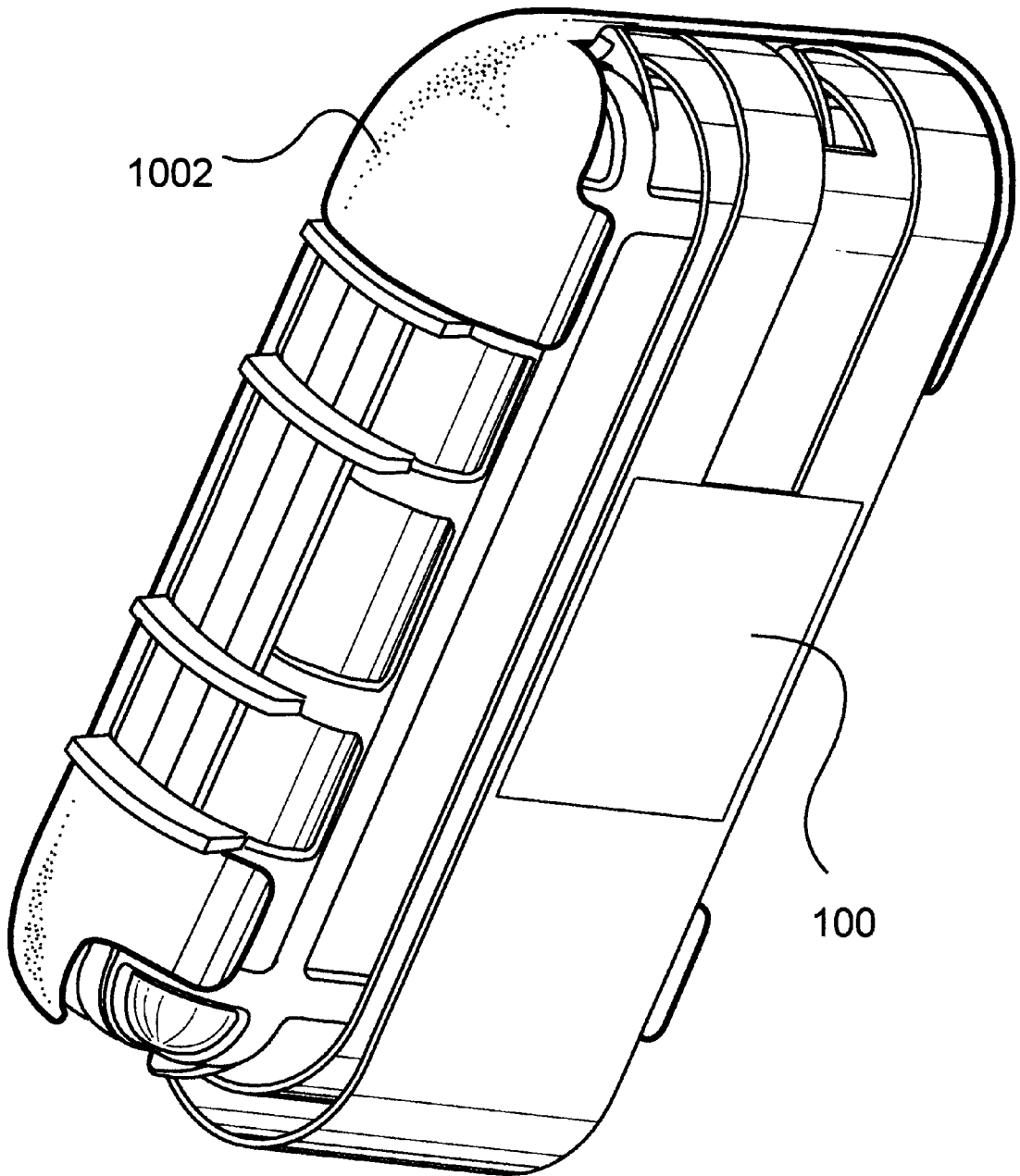

FIGURE 10

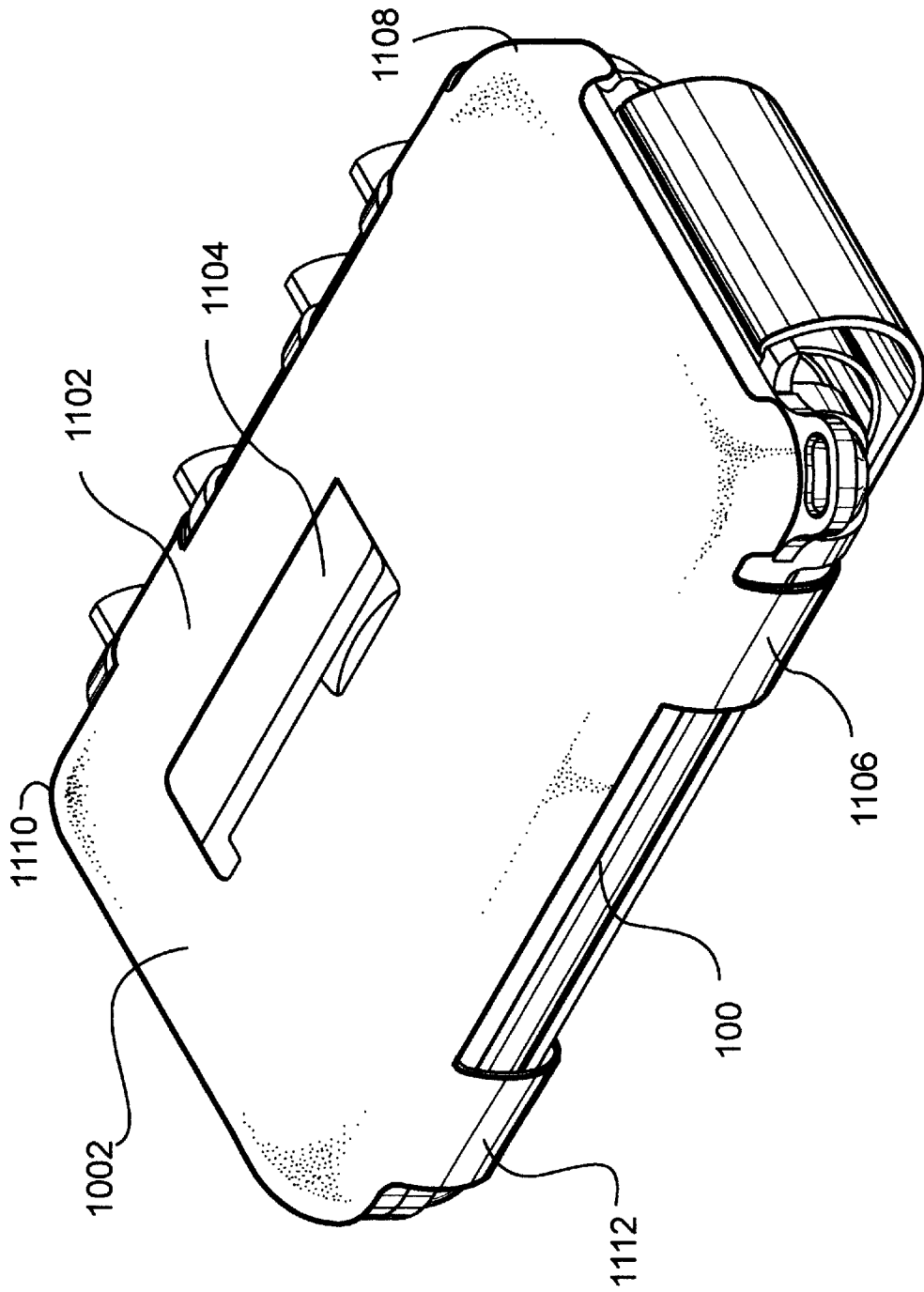

FIGURE 11

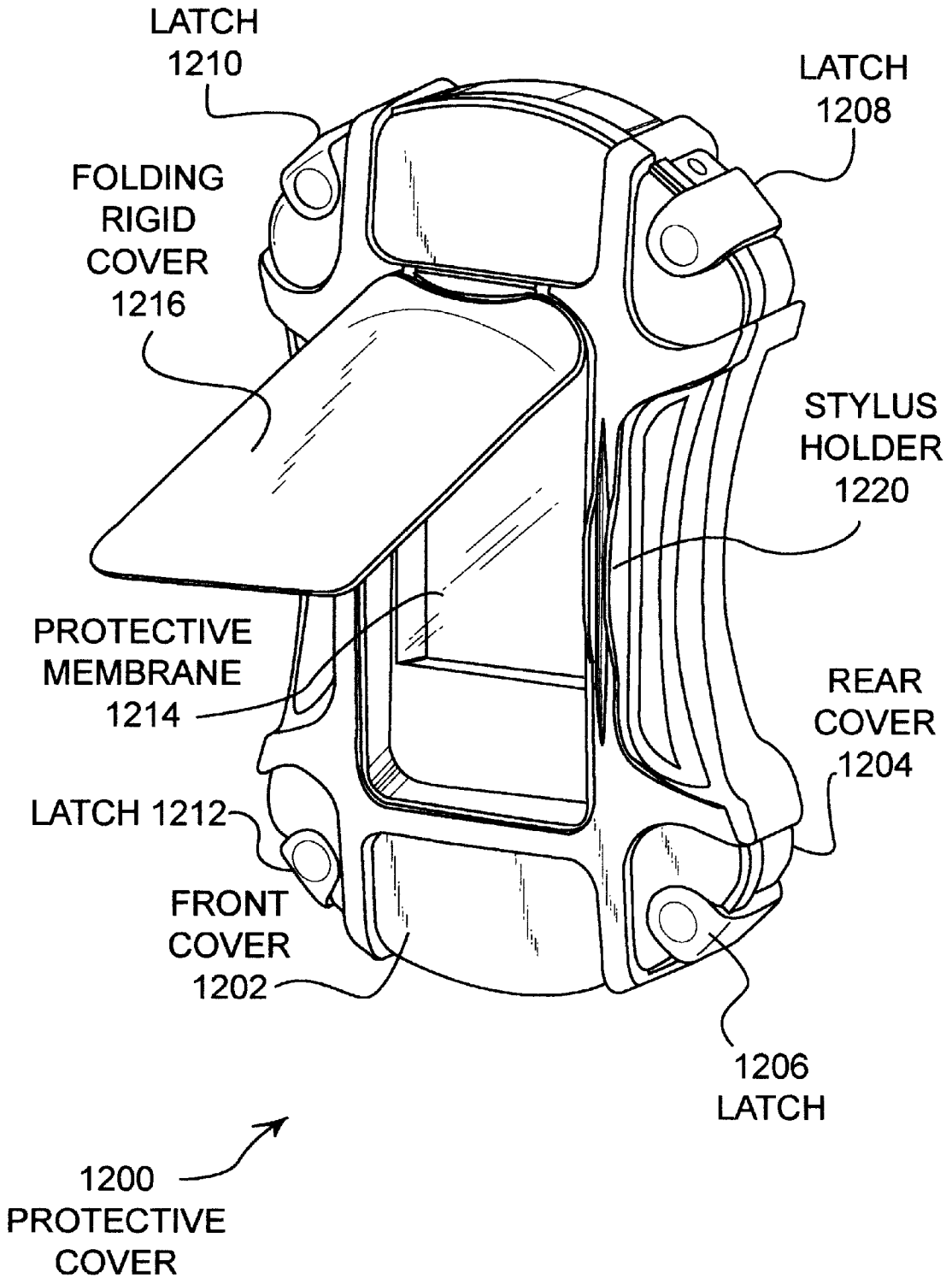

FIGURE 12

PROTECTIVE CASE FOR TOUCH SCREEN DEVICE

CROSS REFERENCE TO RELATED APPLICATIONS

The present application claims priority to and benefit of U.S. Provisional Application Ser. No. 60/335,865 filed Nov. 19, 2001 by Curtis R. Richardson entitled "Protective Case for Touch Screen Device", the entire contents of which are hereby specifically incorporated by reference for all it discloses and teaches.

BACKGROUND OF THE INVENTION

a. Field of the Invention

The present invention pertains generally to protective cases and specifically to protective cases for devices that have a touch screen interface.

b. Description of the Background

Personal Digital Assistants, or PDAs are being very widely used, and are being deployed in industrial as well as office environments. PDAs are being used in industrial environments for data collection, such as service information on an airplane, or for data delivery such as maps for fire fighters and other emergency personnel. When PDAs are deployed in such industrial applications, the data that is collected and displayed on the PDA can be extremely valuable and can be life saving.

The industrial environments impose harsh conditions that typical PDAs are not designed to accommodate. For example, damage can be done to the PDA through rough handling and dropping. Further, industrial chemicals, grease, water, dirt, and grime may damage or destroy a functioning PDA and inhibit the use of the PDAs valuable data.

It is common to hold the PDAs inside a protective case for transport. However, in the case of a firefighter using the PDA on a fire scene, opening a case with gloved hands in the midst of fighting a fire exposes the PDA to easily being dropped, getting wet, or otherwise being damaged.

The user interface for PDAs are typically a few buttons and a touch screen display. The touch screen is used to both display information and to capture information. The data capture generally uses a stylus to select buttons or areas on the screen for certain functions, draw shapes onto the screen, use character recognition to enter text or numbers, or other methods of data capture.

The PDA may be connected to another computer by several mechanisms. The PDA may be direct connected using a wire connection, wherein a cable with a connector physically connects to the PDA. A second method is to use an infrared communication protocol that uses an infrared transmitter and receiver mounted in the PDA to communicate with another computer having a similar transceiver. A third method is to communicate via radio signals such as a cellular phone protocol or wireless modem.

It would therefore be advantageous to provide a case for a PDA wherein the PDA may be fully operated when the PDA is stored securely in the case. Further, the operation of the PDA through its touch screen interface should not be hindered by a protective case. The case would also not interfere with the connections between the PDA and another computer.

SUMMARY OF THE INVENTION

The present invention overcomes the disadvantages and limitations of the prior art by providing a protective case

whereby a touch screen display may be viewed and manipulated without impeding the performance of the display and for use while the device is protected by the case. The touch screen interface is comprised of a semi rigid translucent material that is stiff enough and smooth enough for the stylus to move over the surface of the material without digging into the surface of the material and still being flexible enough so that the touch screen may be operated.

Further, the present invention may allow infrared and other types of communications between a device inside the case and an external electronic device while the device is maintained in the protective case. The present invention also may allow for optional direct electrical connections to be made through the case without having to open the case. Additionally, pass-throughs for light, acoustics, heat, mechanical actuation, etc. may also be provided.

The present invention may further comprise a belt clip for holding the case on a person's belt. The belt clip may be designed so that the touch screen interface is oriented toward the user's body for optimal protection from damage.

The present invention may therefore comprise a cover for a touch screen electronic device comprising: a shell comprising an opening; a membrane comprising a portion of the membrane adapted to contact the touch screen and a periphery of the membrane adapted to be attached to the shell within the opening, the membrane being flexible to allow the touch screen device to be operated; the membrane having a portion through which a button on the device may be activated; the membrane being replaceable; the membrane having a textured exterior surface; an electrical pass through adapted to communicate electrical signals through the shell; an infrared pass through adapted to communicate infrared signals through the shell; an acoustical pass through adapted to communicate acoustical signals through the shell; a light pipe adapted to communicate light from the device to the exterior of the shell; a heat sink adapted to communicate heat from the device to the exterior of the shell; a receiver with a belt clip adapted to accept the shell; and the receiver adapted to orient the device so that the touch screen is facing towards the belt clip.

The present invention may further comprise a cover for a touch screen device comprising: a shell for containing the touch screen device; a portion of the shell having a flexible membrane disposed over the touch screen of the touch screen device and adapted to allow the tactile inputs to be communicated to the touch screen.

The present invention may further comprise a method of protecting an electronic device with a touch screen comprising: providing the electronic device; providing a protective cover comprising a shell for containing the electronic device, a portion of the shell having a flexible membrane adapted to allow the tactile inputs to be communicated to the touch screen; and placing the electronic device in the protective cover such that the flexible membrane is disposed against the touch screen.

The present invention may further comprise a cover for a touch screen electronic device comprising: a first means for holding the touch screen electronic device; a second means for covering the touch screen of the touch screen electronic device adapted to allow the operation of the touch screen when placed against the touch screen; and a third means for removably securing the second means to the first means.

The advantages of the present invention are that PDAs and other electronic devices comprising touch screens may be used in the most severe operating environments without damage. Further, various functions of the electronic devices

may be available to the user, including portability, direct electrical connection, infrared transmit and receive, radio transmit and receive, direct operation of every button, and full viewing and manipulation of the touch screen interface.

BRIEF DESCRIPTION OF THE DRAWINGS

In the drawings,

FIG. 1 is a perspective view of an embodiment of the invention shown in the closed position.

FIG. 2 is a perspective view of an embodiment of the invention shown in the open position.

FIG. 3 is a perspective view of an embodiment of the invention shown in an exploded state.

FIG. 4 is a perspective view of an embodiment of the invention shown from the rear.

FIG. 5 is a front view of an embodiment of the invention, showing a section line.

FIG. 6 is a section view of an embodiment of the invention.

FIG. 7 is a detailed view of a section shown in FIG. 6.

FIG. 8 is a perspective view of another embodiment comprising a single piece encapsulating cover.

FIG. 9 is a perspective view of a third embodiment comprising a non-encapsulating snap over cover.

FIG. 10 is a perspective view of an embodiment that comprises a belt clip.

FIG. 11 is a second perspective view of an embodiment that comprises a belt clip.

FIG. 12 is a perspective view of another embodiment of the present invention of a protective cover for a PDA or other device.

DETAILED DESCRIPTION OF THE INVENTION

FIG. 1 is a perspective view of an embodiment of the invention. Embodiment **100** comprises a rigidly molded front case **102** and rear case **104**. An overmolded grommet **106** forms a receptacle for stylus **108** and also aids in sealing membrane **110**. A flexible hand strap **112** attaches to the rear case **104**. A hinge **114** joins front case **102** and rear case **104**. A ring **124** for a lanyard is shown as an integral feature of rear case **104**.

Embodiment **100** is designed to hold a conventional personal digital assistant (PDA) in a protective case. A PDA, such as a Palm Pilot, Handspring Visor, Compaq Ipaq, Hewlett Packard Jornada, or similar products use a touch screen for display and data entry. The touch screen display comprises either a color or black and white liquid crystal display with a touch sensitive device mounted on top of the display. The display is used for displaying graphics, text, and other elements to the user. The touch screen is used with a stylus **108** to select elements from the screen, to draw figures, and to enter text with a character recognition program in the PDA. The stylus **108** generally resembles a conventional writing implement however, the tip of the writing implement is a rounded plastic tip. In place of a stylus **108**, the user may use the tip of a finger or fingernail, or a conventional pen or pencil. When a conventional writing implement is used, damage to the touch screen element may occur, such as scratches.

For the purposes of this specification, the term PDA shall include any electronic device that has a touch screen interface. This may include instruments such as voltmeters, oscilloscopes, logic analyzers, and any other hand held,

bench top, or rack mounted instrument that has a touch screen interface. Hand held devices, such as cell phones, satellite phones, telemetric devices, and other hand held devices are also to be classified as PDAs for the purposes of this specification. The term PDA shall also include any computer terminal display that has a touch screen interface. These may comprise kiosks, outdoor terminal interfaces, industrial computer interfaces, commercial computer interfaces, and other computer displays. Additionally, the term PDA may comprise barcode scanners, hand held GPS receivers, and other handheld electronic devices. The foregoing-description of the term PDA has been presented for purposes of illustration and description. It is not intended to be exhaustive or to limit the invention to the precise forms disclosed, and other modifications and variations may be possible in light of the teachings of this specification.

In addition, the PDAs typically have a handful of additional buttons as part of the user interface. These buttons are generally on the front of the device, near the touch screen element. The additional buttons may be used as shortcut buttons to instantly call up a certain program on the PDA, may comprise a method of scrolling, may be used to select items from a list, or may have any function that the designer of the PDA software may assign to the button or set of buttons. The button size, layout, and function may vary for each manufacturer and model of PDA.

Further, PDAs typically have at least one method of connecting to another computer. This may be through a direct electrical connection, such as through a wire cable or fiber optic, or through another medium such as infrared communication or through a radio communication.

Additionally, the PDAs typically have an electrical source. The electrical source may be a rechargeable or non-rechargeable battery or solar cells. The electrical source may be a remote source of electricity that is transmitted to the PDA through a wire cable or through other methods of electrical transmission.

Further, PDAs may have indicator lights, such as status lights for power, communication, battery status, or other functions. The lights may be located on any of the sides of the PDA and may be viewable on one or more sides.

Front case **102** and rear case **104** form a protective cover for the PDA. The protective cover may be designed for rugged industrial use, recreational use, commercial use, or many other uses. An industrial use may require the protective cover to be watertight, chemically resistant, protect the unit when dropped, and be crush proof. A typical application may be for fire fighters to use a PDA for a display of maps for directions to an emergency scene or for a building plan at the scene of a fire. Another example may be a maintenance mechanic in a chemical plant using a PDA to record maintenance records in the plant that processes. A recreational use may require the cover to be watertight, afford some protection against dropping and being crushed, float in water, and be dust resistant. A recreational use may be to take the PDA during kayaking, diving, or other water sport activity. Further, the case may be used when the PDA is taken camping, hiking, or other outdoor activity. A commercial use may additionally require the protective cover to be elegant, but may also require the cover to be replaceable so that scratches and other signs of wear and tear can be easily and cheaply replaced.

The protective cover for the PDA may take on many embodiments. The embodiment **100** comprises a front case **102** and rear case **104** that are joined by a hinge **114** and a clasp mechanism that is on the side of the cases opposite the

hinge **114**. Other embodiments may have a small door into which the PDA slides, or the protective cover may not completely enclose the PDA and only cover the face where the user interface exists, leaving one or more sides of the PDA exposed. Those skilled in the art may use other designs of protective covers without deviating from the scope and intent of the present invention.

The protective cover may be constructed of rigid plastic, metal, flexible rubber, or any other type of material that could be adapted to afford the protection of the PDA desired for the application. For example, a metal cover may be used in an application where an elegant style is necessary but watertightness is not. A flexible rubber cover may be selected for an application in a wet environment. A rigid plastic cover may be selected for an application where dropping the PDA is a concern. Those skilled in the art may use other types of materials and constructions without deviating from the spirit of the present invention.

The PDA may be mounted in the protective cover using many different mounting techniques. For example, the PDA may be mounted using open or closed cell foam inserts in the protective cover. In another embodiment, the PDA may be mounted by attaching the PDA to the cover with a fastener. In another embodiment, the PDA may be mounted by snapping into the protective waterproof cover. In another embodiment, the PDA may be held in place by resting in molded features of two halves of a protective case that clamps onto the PDA. Those skilled in the art may use other types of locating and holding mechanisms without deviating from the spirit of the present invention.

The overmolded grommet **106** of the present embodiment is constructed by injection molding a thermoplastic polymerized rubber (TPR) over the front case **102**. The grommet **106** has molded features **116** and **118** adapted to retain the stylus **108**. Features **116** and **118** capture the stylus **108** during transportation, but allow the user to remove the stylus **108** to operate the PDA. In other embodiments of the present invention, the stylus **108** may be constrained to the PDA with a tether or lanyard, or the constraining features may be incorporated into other components that make up the protective cover. Further, the stylus **108** may not be present in the embodiment, rather that the PDA be adapted to be used with the user's fingernail or with another implement similar to the stylus **108**.

The membrane **110** of the present embodiment is constructed by thermoforming a sheet of thin plastic. The plastic is selected to be thin enough that the deformation of a stylus conducts the touch to the touch screen, but thick enough to have enough rigidity that the stylus does not catch and rip the membrane. Additionally, the membrane **110** should have enough thickness to endure scratches and other wear and tear without breaking and sacrificing the protective function. Polyvinylchloride material at 0.010 in to 0.015 in thickness gives acceptable results. Alternatively, membrane **110** may be constructed by injection molding or other methods. Alternative materials may be used by those skilled in the art to achieve the same results while maintaining within the spirit and intent of the present invention.

The membrane **110** in the present embodiment may be translucent, so that the images displayed on the PDA may be visible through the membrane **110**. The membrane **110** may be tinted or colorized in some applications. For example, a protective cover designed as a decorative cover may incorporate a colorized membrane **110**. Further, the membrane may be selectively colorized and the opaqueness may vary. For example, the protective membrane may be printed or

printed in the areas not used for the touch screen. A printing process may incorporate a logo, graphics, or labeling for individual buttons for the PDA. The printing process may further incorporate features, such as text or graphics, that are used by the software on the PDA for a purpose such as simplifying data input or for designating an area on the touch screen for a specific function, such as a help function. The printing or painting processes used on the membrane **110** may be purely decorative and may be for aesthetic purposes only. The printing process may also comprise logos or graphics for the brand identity of the PDA cover. Other processes, such as colorizing the raw material for the membrane **110** or adding other components to the raw material, such as metal flakes or other additives, may be used to change the optical features of the membrane **110**.

The optical performance of the membrane **110** may be changed or enhanced by changing the texture of the area of the touch screen. For example, the membrane may be frosted on the outside to hide scratches or may be imprinted with a lens or other features that change the optical characteristics of the membrane **110**. The membrane **110** may have optical features that are used in conjunction with the software of the PDA. For example, all or a portion of the membrane may comprise a lens that magnifies an image to a user. When the user touches the image on the membrane **110** and the touch is transferred to the touch screen, the software in the PDA may have to compensate for the positional differences between the image and actual area that was touched by the user. In another example, if a specific portion of the membrane **110** had a specific optical characteristic, the software of the PDA may be constructed to display a specific graphic for the area for an intended effect.

The membrane **110** in the present embodiment has a recessed portion **120** and a raised portion **122**. The recessed portion **120** may be adapted to press flat against the touch screen area of a specific PDA. The raised portion **122** may be adapted to fit over an area of the specific PDA where several buttons are located.

The raised portion **122** allows the user to operate the buttons on the PDA. The raised portion **122** is adapted such that the buttons on the PDA are easily operated through the protective membrane **110**. The raised portion **122** may have special features to aid the user in pressing the buttons. For example, the raised portion **122** may comprise a dimpled area for the user's finger located directly over the button. Further, a feature to aid the user may comprise a section of membrane **110** defined by a thinner area around the section, enabling the user to more easily deflect the section of membrane over the button. The area of thinner material may comprise a large section or a thin line. Further, tactile elements, such as small ribs or bumps may be incorporated into the membrane **110** in the area of the buttons so that the user has a tactile sensation that the user's finger is over the button. The tactile element may be particularly effective if the button was a power switch, for example, that turned on the PDA.

The configuration of the membrane **110** may be unique to each style or model of PDA, however, the front case **102** and rear case **104** may be used over a variety of PDAs. In the present embodiment, the changeover from one PDA variety to another is accomplished by replacing the membrane **110** without having to change any other parts. The present embodiment may therefore be mass-produced with the only customizable area being the membrane **110** to allow different models of PDAs to be used with a certain front case **102** and rear case **104**.

The hand strap **112** in the present embodiment allows the user to hold the embodiment **100** securely in his hand while

using the PDA. The hand strap **112** may be constructed of a flexible material, such as rubber or cloth webbing, and may have an adjustment, such as a buckle, hook and loop fastener, or other method of adjustment. In other embodiments, a hand strap may be a rigid plastic handle, a folding handle, or any other method of assisting the user in holding the embodiment. Further, the embodiment may be adapted to be fix-mounted to another object, like a piece of machinery, a wall, or any other object. A fix-mounted embodiment may have other accoutrements adapted for a fixed mount applications, such as receptacles for a stylus adapted to a fix-mount, specialized electrical connections, features for locking the PDA inside the case to prevent theft, or designs specifically adapted to shed water when rained upon.

FIG. 2 illustrates a perspective view of the embodiment **100** shown in an open position. The front case **102** and rear case **104** are shown open about the hinge **114**. Membrane **110** is shown installed into gasket **106**, and the recessed portion **120** and raised portion **122** of membrane **110** is illustrated looking from the inside of the case. The clasp mechanisms are not shown in this illustration. Hand strap **112** is shown attached to rear case **104**.

FIG. 3 illustrates a perspective view of the embodiment **100** shown in an exploded state. The hand strap **116** attaches to the rear cover **104**. The overmolded grommet **106** holds the stylus **108** and is attached to front cover **102**. The membrane **110** attaches to the grommet **106** and is held in place with an o-ring **302**.

FIG. 4 illustrates a perspective view of the embodiment **100** shown from the rear. The hand strap **116** is shown, along with rear cover **104** and front cover **102**. The stylus **108** is shown inserted into the overmolded grommet **106**.

FIG. 5 illustrates a top view of the embodiment **100**. The front cover **102**, membrane **110**, stylus **108**, and hinge **114** are all visible.

FIG. 6 illustrates a section view of the embodiment **100** taken through the section line shown in FIG. 5. The front cover **102**, rear cover **104**, overmolded gasket **106**, stylus **108**, membrane **110**, hand strap **112**, and o-ring **302** are all shown hatched in this view.

FIG. 7 illustrates a detail view of the embodiment **100** shown in FIG. 6. Front case **102** and rear case **104** are joined at hinge **114**. Overmolded gasket **106** traps membrane **110** and o-ring **302** locks membrane **110** in place. Overmolded gasket **106** may be formed by molding thermoplastic polymerized rubber over the front cover **102**.

The replacement of the membrane **110** is accomplished by removing o-ring **302**, pushing the membrane **110** from the overmolded gasket **106**, snapping a new membrane **110** into place, and replacing the o-ring **302**. The ease of replacement of the present embodiment allows a user to quickly replace a damaged membrane **110**, allows a user to upgrade their case to a newer model PDA, and may allow a user to select from various membranes **110** for the particular application. One embodiment may have a single case packaged with a small variety of several types of membranes **110**. In such an embodiment, the user may purchase the packaged set, select the membrane **110** that suits the user's particular PDA, and install the selected membrane **110** with ease.

The protective cover of the present invention may have direct connections through the cover for connecting through the case. Such a connection is known as pass through. The connections may be for power, communication, heat dissipation, optical transmissions, mechanical motion, or other reasons.

Electrical connections may require an insulated metal conductor from the PDA through the wall of the protective cover so that a flexible cable may be attached or so that the PDA in its protective case may be placed in a cradle for making the electrical connection. Inside the protective cover, the electrical connections may be made with a flexible cable that is plugged into the PDAs electrical connector before the PDA is secured in the protective cover. Alternatively, a fixed connector may be attached to the protective cover and the PDA is slid into contact with the fixed connector. Another embodiment may be for a compliant, yet fixed mounted electrical connector to be rigidly mounted inside the protective cover. A compliant, yet fixed mounted electrical connector may comprise spring loaded probes, commonly referred to as pogo pins. Another embodiment may comprise spring fingers that engage the PDAs electrical contacts. On the outside of the protective cover, the electrical contacts may be terminated into a fix-mounted connector adapted to receive a cable from a computer. The connector may be designed to receive a cable that plugs directly into the PDA or it may be adapted to receive a different connector. Further, the electrical connection to the PDA may be permanently attached to a cable that extends out of the protective cover. Another embodiment may be to have a small trap door that opens in the protective cover to allow access to the electrical connections. While the trap door exposes the PDA to the elements the cover is designed to protect against, a direct electrical connection may eliminate a potential cabling connection problem. Connections for fiber optics can be handled in similar fashions as the electrical connections. An embodiment with a power connection may comprise the use of inductive coils located in proximity to each other but on opposite sides of the protective cover. Those skilled in the art of may devise other embodiments for connecting through the protective cover without deviating from the scope and intent of the present invention.

Through the air communications, such as infrared and over the air radio frequency (RF) communications may pass through the protective cover. The material for the front case **102** and rear case **104** may be selected to be clear plastic, such as polycarbonate. The infrared transceiver of the PDA can communicate through a clear plastic case to another infrared transceiver outside of the case. Further, the appropriate selection of material for the protective case can thereby enable various RF transmissions, such as cellular phone communications or other wireless communication protocols.

An infrared transmission through the protective case of an embodiment of the invention may be accomplished by making the entire protective case out of a clear material. Alternatively, a selected area of the protective case may be clear while the remainder of the case is opaque. The selected area may be constructed of a separate piece that allows the infrared light through the protective case. Alternatively, the selected area may be constructed of a portion of the protective case that manufactured in a way so as not to be opaque, such as selectively not painting or plating the area of a plastic protective case. Further, the clear material through which the transmission occurs may be tinted in the visual spectrum but be translucent in the infrared spectrum of the device.

A protective case may allow RF transmissions to and from the PDA while the case is closed. Such a case may be constructed of a non-metallic material. In some embodiments, the material of the protective case may be tuned to allow certain frequencies to pass through the

protective cover and tune out other frequencies, through loading the material used in the protective cover with conductive media or through varying the thickness of the case and other geometries of the case in the area of the PDA transmission and reception antenna.

In a different embodiment, it may be desirable to shield the PDA from outside RF interference. In this case, the protective cover may be a metallic construction or may be plastic with a metallized coating. Further, membrane **110** may have a light metallized coating applied so that membrane **110** is slightly or fully conductive. An application for such an embodiment may be the use of the PDA in an area of high RF noise that may interfere with the operation of the PDA, or conversely, the use may be in an area that is highly susceptible to external RF interference and the PDAs RF noise may be interfering with some other device.

The PDA may be equipped with a camera or other video capture device. A protective cover may have provisions to allow a clear image to be seen by the video capture device through the case. Such provisions may include an optically clear insert assembled into the protective case. Other embodiments may have a sliding trap door whereby the user of the PDA may slide the door open for the camera to see. Additionally, other embodiments may comprise a molded case that has an optically clear lens integrally molded. Such an embodiment may be additionally painted, plated, or overmolded, with the lens area masked so that the painting, plating, or overmolding does not interfere with the optics of the lens.

An optically clear area may be used for a barcode scanner portion of a PDA to scan through the case to the outside world. In such an embodiment, a barcode scanner may be protected from the elements while still maintaining full functionality in the outside world.

The PDA may have indicator lights that indicate various items, such as power, battery condition, communication, and other status items. The indicator lights may be in positions on the PDA that are not readily viewable through the protective membrane **110**. The indicator lights may be made visible through the protective case by using light pipes that transmit the light from the PDAs status light to the outside of the protective case. Such light pipes may be constructed of clear or tinted plastic, or other translucent or semi-translucent material. The light pipes may be formed as an integral feature to the protective case or may be separate parts that are formed separately and assembled to the protective case.

The PDA may have a speaker or other element that makes noise and/or the PDA may have a microphone for receiving audio signals. The speaker may be an audio quality device for reproducing sound or it may be a simple buzzer for indicating various functions of the PDA. The microphone may be an audio quality device or it may be a low performance device. Special provisions may be made for transmitting sound through a protective case. Such provisions may range from a single hole in the case to a tuned cavity that would allow sound to pass through with minimum distortion. Other embodiments may include a transmissive membrane adapted to allow sound to pass through the protective case with a minimum of distortion. Such membranes may be located near the speaker and microphone elements of the PDA. Such membranes may be watertight membranes known by the brand name Gore-Tex.

The PDA may generate heat during its use and provisions for dissipating the heat may be built into the protective cover. A heat-dissipating device may be integral to the

protective cover or may comprise one or more separate parts. For example, a metallic protective cover may be adapted to touch the PDA in the area of heat generation and conduct the heat outwardly to the rest of the protective cover. The protective cover may thereby dissipate the heat to the external air without overheating the PDA. In another example, a separate heat sink may be applied to the PDA and allowed to protrude through a hole in the protective cover. The heat sink may thereby transfer the heat from the PDA to the ambient environment without overheating the PDA. The heat sinks may be attached to the PDA with a thermally conductive adhesive. Other embodiments may include vent holes for heat dissipation and air circulation.

The PDA may have a button that may not be located underneath the membrane **110**. An embodiment may include a flexible, pliable, or otherwise movable mechanism that may transmit mechanical motion from the outside of the case to a button on the PDA. Such an embodiment may have a molded dimpled surface that is pliable and allows a user to activate a button on a PDA by pressing the dimpled surface. Another embodiment may have a rigid plunger that is mounted on a spring and adapted to transmit the mechanical movement from the exterior of the case to a button on the PDA. The buttons on the PDA may be located on any side of the PDA and an embodiment of a case may have pliable areas adapted to allow the user to press buttons that are not on the front face of the PDA.

FIG. 8 is an illustration of embodiment **800** of the present invention wherein the PDA **802** is encapsulated by a protective cover **804**. The installation of the PDA **802** is to slide PDA **802** into the opening **808**, then fold door **806** closed and secure with flap **810**, which is hinged along line **812**. Areas **814** and **816** may comprise a hook and loop fastener system or other fastening device. Recessed area **818** is adapted to fit against touch screen **820** of PDA **802**.

Embodiment **800** may be comprised of a single molded plastic part that may be very low cost. As shown, embodiment **800** may not be completely weathertight, since the door **806** does not completely seal the enclosure. However, such an embodiment may afford considerable protection to the PDA **802** in the areas of dust protection, scratch protection, and being occasionally rained upon. Further, the low cost of the embodiment **800** may be changed often during the life of the PDA **802**.

Embodiment **800** may have custom colors, logos, or designs that allow a user to personalize their PDA with a specific cover that is suited to their mood or tastes. The colors, logos, and designs may be integrally molded into the cover **804**. Alternatively, different colors, logos, and designs may be applied in a secondary operation such as printing, painting, plating, or other application process.

FIG. 9 is an illustration of embodiment **900** of the present invention wherein a decorative cover **902** is snapped over a PDA **904**. The ends **906** and **908** snap over the PDA ends **910** and **912** as an attachment mechanism for cover **902** to PDA **904**. Recessed area **914** is adapted to fit against touch screen **916**.

Embodiment **900** may be a cover for decorative purposes only, or may be for protective purposes as well. Cover **902** may be emblazoned with logos, designs, or other visual embellishments to personalize the PDA **904**. The colors, logos, and designs may be integrally molded into the cover **904**. Alternatively, different colors, logos, and designs may be applied in a secondary operation such as printing, painting, plating, or other application process.

Embodiment **900** may be attached by snapping the cover **902** onto PDA **904**. Special provisions in the case of PDA

11

904 may be provided for a snapping feature of cover **902**, or cover **902** may be adapted to hold onto PDA **904** without the use of special features in PDA **904**.

The features used to secure cover **902** to PDA **904** may be any mechanism whereby the cover **902** can be secured. This includes snapping, clamping, fastening, sliding, gluing, adhering, or any other method for securing two components together.

FIG. **10** illustrates a perspective view of an embodiment of a receiver **1002** for holding the protective case **100**. The protective case **100** is held into receiver **1002** in such a manner that the touch screen display is facing into the receiver **1002**, to afford the touch screen display with protection.

FIG. **11** illustrates a perspective view of the embodiment of a receiver **1002** shown from the opposite side as FIG. **10**. Receiver **1002** is comprised of a back **1102**, a belt clip mechanism **1104**, and four clip areas **1106**, **1108**, **1110**, and **1112**. The protective case **100** is placed into the receiver **1002** by inserting one end into the receiver, then rotating the protective case **100** into position such that the snapping action of clip areas **1106**, **1108**, **1110**, and **1112** are engaged to hold protective case **100** securely.

Receiver **1002** may be adapted to clip onto a person's belt or may be adapted to be mounted on a wall or other location where the PDA may be stored. The orientation of the protective case **100** is such that the touch screen element of the PDA is protected during normal transport and storage, since the touch screen interface is facing the back **1102** of the receiver **1002**.

Receiver **1002** may be made of compliant plastic that allows the clip areas **1106**, **1108**, **1110**, and **1112** to move out of the way and spring back during insertion or removal of the protective case **100**. In the present embodiment, receiver **1002** may be constructed of a single part. In alternative embodiments, receiver **1002** may be constructed of multiple parts and of multiple materials, such as a metal back with spring loaded clips. In other embodiments, special features may be included in the protective case **100** where the receiver **1002** may engage a special feature for securing the protective case **100**.

FIG. **12** illustrates an embodiment **1200** of the present invention of a protective cover for a PDA or other device. A rigid front cover **1202** and a rigid rear cover **1204** are held together with a series of latches **1206**, **1208**, **1210**, and **1212**. The protective membrane **1214** protects the touchscreen of the enclosed PDA. A folding rigid cover **1216** operates as a rigid shield to prevent the membrane **1214** from any damage. The stylus holder **1220** is formed from an overmolded flexible material in which the membrane **1214** is mounted.

Embodiment **1200** illustrates yet another embodiment of the present invention wherein a rigid protective cover may be used to contain and protect an electronic device, but provide full usable access to a touchscreen. The protective membrane **1214** and case may be watertight in some embodiments.

The foregoing description of the invention has been presented for purposes of illustration and description. It is not intended to be exhaustive or to limit the invention to the precise form disclosed, and other modifications and variations may be possible in light of the above teachings. The embodiment was chosen and described in order to best explain the principles of the invention and its practical application to thereby enable others skilled in the art to best utilize the invention in various embodiments and various modifications as are suited to the particular use contem-

12

plated. It is intended that the appended claims be construed to include other alternative embodiments of the invention except insofar as limited by the prior art.

What is claimed is:

1. An enclosure for a touch screen device that allows operation of a touch screen on said touch screen device while said touch screen device is disposed in said enclosure comprising:

a shell that is adapted to contain said touch screen device; a flexible membrane that is connected to said shell and is located in said shell in such a position as to be disposed over said touch screen of said touch screen device when said touch screen device is disposed in said enclosure, said flexible membrane adapted to allow tactile inputs to be communicated to said touch screen wherein said shell comprises a protective case portion adapted to hold said touch screen device; an aperture in said protective case; and said flexible membrane adapted to mount in said aperture wherein said membrane secured in a manner that allows replacement of said membrane.

2. The enclosure of claim 1 wherein at least a portion of said protective case portion is rigid.

3. The enclosure of claim 1 wherein said protective case portion is watertight.

4. The enclosure of claim 2 wherein said protective case portion comprises a flexible portion adapted to receive said flexible membrane.

5. The enclosure of claim 1 further comprising a receiver with a belt clip adapted to accept said cover.

6. The enclosure of claim 1 wherein said flexible membrane comprises printed matter applied to said membrane.

7. The enclosure of claim 1 wherein said flexible membrane has a texture applied to at least a portion of the exterior surface of said flexible membrane.

8. A method of protecting an electronic device with a touch screen comprising:

providing said electronic device;

providing a protective enclosure comprising a shell that is adapted to contain said electronic device, a flexible membrane that is connected to said shell and is located in said shell in such a position as to be disposed over said touch screen and adapted to allow tactile inputs to be communicated to said touch screen; and

placing said electronic device in said protective cover such that said flexible membrane is disposed against said touch screen wherein said enclosure comprises a protective case portion adapted to hold said electronic device; an aperture in said protective case; and said flexible membrane adapted to mount in said aperture wherein said membrane secured in a manner that allows replacement of said membrane.

9. The method of claim 8 wherein at least a portion of said protective case portion is rigid.

10. The method of claim 8 wherein said protective case portion is watertight.

11. The method of claim 9 wherein said protective case portion comprises a flexible portion adapted to receive said flexible membrane.

12. A cover for a touch screen electronic device comprising:

a first means for holding said touch screen electronic device;

a second means for covering the touch screen of said touch screen electronic device adapted to allow the operation of said touch screen when placed against said touch screen; and

13

a third means for removably securing said second means to said first means.

13. The cover of claim **12** wherein said first means comprises a rigid case.

14. The cover of claim **12** wherein said third means comprises a flexible member attached to said first means. 5

14

15. The cover of claim **14** wherein said third means is secured to said second means in a watertight fashion.

16. The cover of claim **12** wherein said first means further protects said electronic device from mechanical shock.

* * * * *